

STANDARD "SLAR" POST AND PANEL INSTALLATION GUIDE (Rectangular Bottom Rail)

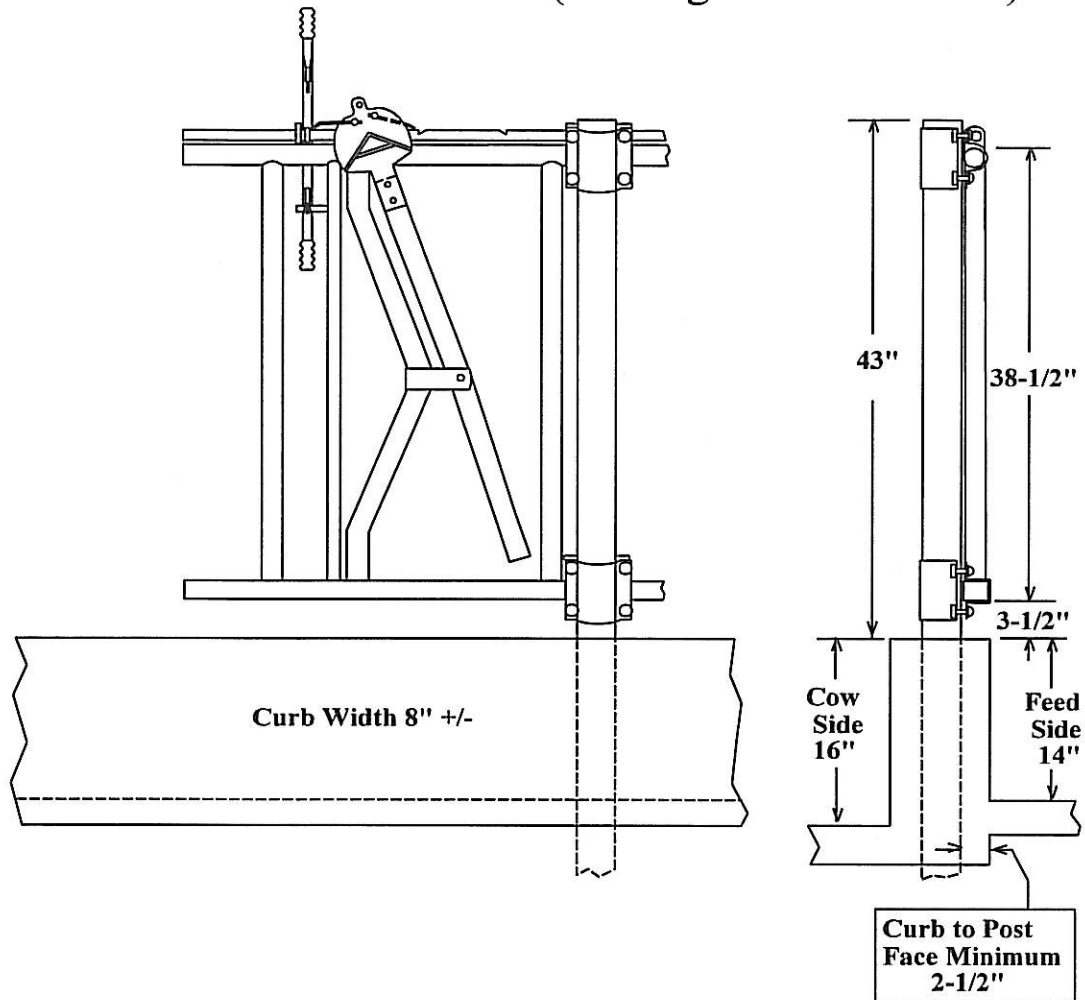

1. Put the first section in place and install clamps on the first post. Tighten bolts snugly, but not fully (note item (4) four). Make sure all sections are facing the same way when installing. Try, although not absolutely necessary, to have the stanchion movables fall with the slope of curb.
2. Place 1" x 5" connecting pipe (included with order - has dimple in center to prevent full insertion) in the ends of the top frame rail and insert alignment clip behind bottom horizontal rail.
3. Slide the next section of stanchions over the top rail connecting pipe and in the alignment clip on the bottom, clamp top and bottom and tighten same as in procedure (1) one.
4. When all sections are installed, align sections (the straighter the better) and fully tighten clamps. Clamps are considered tight when there is an approximate 1/4" gap between the two parts, with the exception of the top clamp where the top two bolts should be tightened first drawing the two pieces completely together.
5. Install handle assembly and then weld the top rail of each section together starting from the handle either direction. (Refer to handle installation sheet for both procedures)

Note: SLAR with rectangular bottom rail will have a round stanchion clamp for top attachment and a rectangular stanchion clamp for bottom attachment.